

Paramount ME Versa-Plate, Version B

Notes:

1. All mounting holes are counterbored from bottom of plate for 1/4" SHCS
2. 3" and 7.5" circular mounting holes attach to the ME Dec Gear using 8 1/4-20 SHCS and 4 10-32 flathead screws
3. Used on Paramounts shipped after November, 2010
4. All mounting holes same dimensions as Version A
5. Lightening holes have changed and Version B Versaplate is approx 20oz heavier.

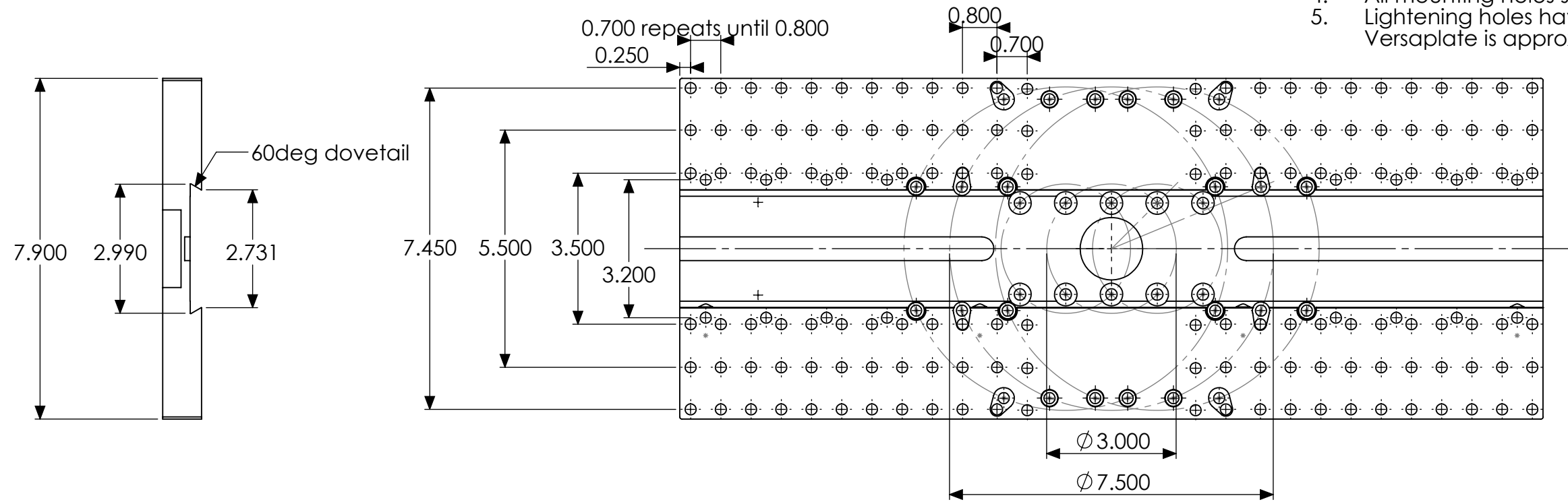

Rev B:

1. Added beginning dimension of 0.250 on top view

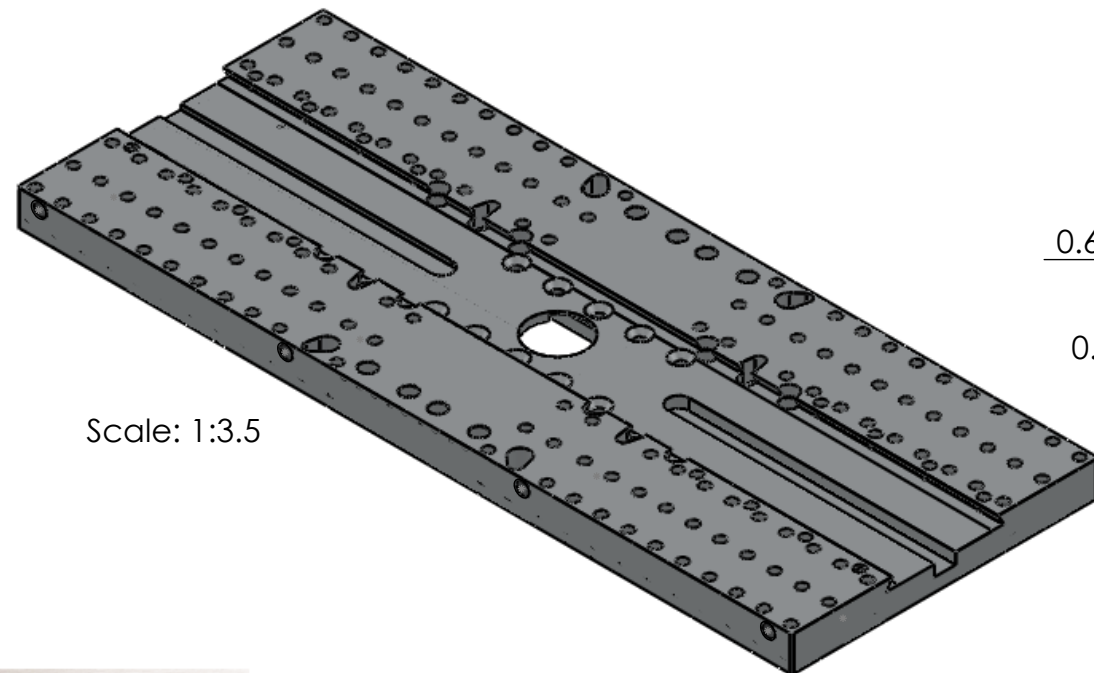

Scale: 1:3.5

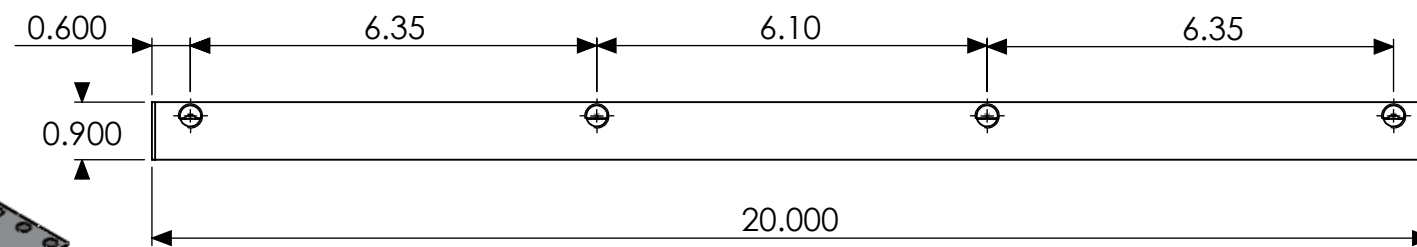

PROPRIETARY AND CONFIDENTIAL
 THE INFORMATION CONTAINED IN THIS DRAWING IS THE SOLE PROPERTY OF SOFTWARE BISQUE. ANY REPRODUCTION IN PART OR AS A WHOLE WITHOUT THE WRITTEN PERMISSION OF SOFTWARE BISQUE IS PROHIBITED.

Stock Size
 Fixturing
 Assembly
 Number

DIMENSIONS ARE IN INCHES
 TOLERANCES:
 FRACTIONAL ±
 TWO PLACE DECIMAL ± 0.020
 THREE PLACE DECIMAL ± 0.005
 MATERIAL:
 6061 Aluminum
 FINISH:
 DO NOT SCALE DRAWING

INITIALS DATE
 DRAWN
 CHECKED
 ENG APPR.
 MFG APPR.
 Q.A.
 COMMENTS:

Software Bisque

Project: **Paramount ME**
 Part Name:
ME Versa-Plate

SIZE DWG. NO. Rev
A **B**
 SCALE: 1:3 WEIGHT: 6.08lbs SHEET 1 OF 1